

※ Thank you for choosing the RS485-1M2S extension module.  
 ※ Please read this manual carefully before using the product.

## RS485-1M2S Extension Module

### 1 Overview

The RS485-1M2S extension module is an optional accessory that can extend the RS485 communication port of our solar controller/inverter. Based on the standard Modbus protocol, the user can monitor the operating status and set parameters through the monitoring devices connected to the RS485-1M2S extension module. The RS485-1M2S main port 1-1 and 1-2 are connected in parallel, which can connect 1 or 2 slave devices, such as a solar controller/inverter. And the RS485-1M2S slave port 2 and 3 are independent, which can connect 1 or 2 monitoring devices at the same time, such as remote meter/WIFI module/Bluetooth module/PC software, etc.

#### Features:

- Extend the RS485 communication port of the solar controller/inverter
- Data interaction between the solar controller/inverter and monitoring devices
- Standard Modbus communication protocol
- One key to set the communication baud rate
- LED screen

### 2 Appearance

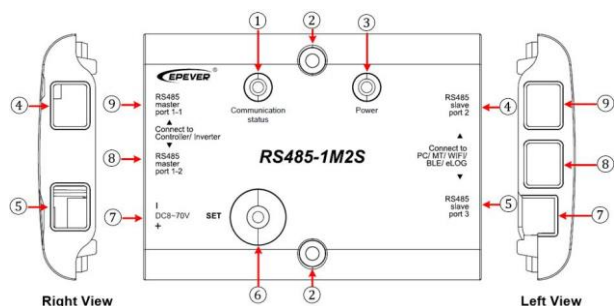

#### ① Communication status Indicator

- Green ON solid -- RS485-1M2S standby
- Green flashing -- RS485-1M2S communicating
- Red flashing -- RS485-1M2S baud rate setting

#### ② Mounting Hole 2-φ4.8mm

#### ③ Power Indicator

- Green ON solid --Power supply normal

#### ④ RS485 slave port 2 (RJ45)

#### ⑤ RS485 slave port 3 (RJ45)

Port④and⑤are independent, which can connect monitoring devices such as remote meter/WIFI module/Bluetooth module/PC software etc.

#### ⑥ Set button

- 9600 - Communication status red indicator flashes once
- 115200-Communication status red indicator flashes twice
- Long press the **Set** button to set the communication baud rate of RS485-1M2S, which is consistent with the communication baud rate of the connected controller/inverter.

#### ⑦ Auxiliary port for external power(5.08-2P)

DC power range: DC 8-70V

DC power source: Battery

Function: When the power consumption of the external monitoring device is large, an external power connected to the auxiliary port can be used to power the device. Detail scenarios are as follows.

Scenario	Device (main port)	Device (slave port)	External power
1	Only controller/ only inverter	MT75+WIFI/ BlueTooth+WIFI/ eLog+WIFI	Yes
2	Controller + inverter	MT75+WIFI/ BlueTooth+WIFI/ eLog+WIFI	No

3	Only controller/ only inverter/ controller + inverter	MT75/BlueTooth/ eLog/WIFI	No
---	---	------------------------------	----

#### ⑧ RS485 main port 1-1(RJ45)

#### ⑨ RS485 main port 1-2(RJ45)

Port ⑧ and ⑨ are connected in parallel, which extend the RS485 communication port by connecting the solar controller/inverter.

### 3 Pin definition for the RS485 communication port

1/2	5VDC
3/4	RS485-B
5/6	RS485-A
7/8	GND

### 4 Accessories

Included Accessories	RS485 cable(length: 1.5m) Model: CC-RS485-RS485-150U	2 pcs
	5.08-2P terminal	1 pcs
Optional Accessories	RS485 adapter(length: 1.5m) Model: CC-USB-RS485-150U	1 pcs

### 5 Connection Diagram

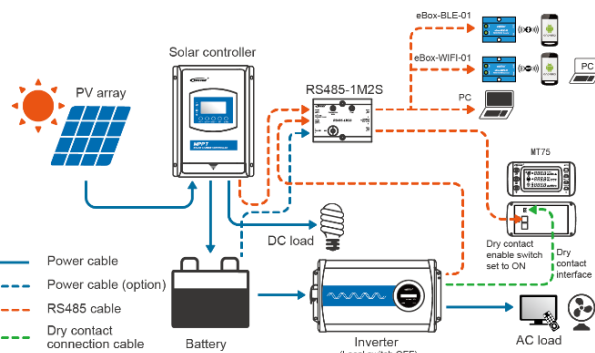

Note: When the power consumption of the external monitoring device is large, an external power connected to the auxiliary port can be used to power the device.

### 6 Specifications

Model	RS485-1M2S
Compatible products	Solar controller/inverter
Power supply	5VDC (Power supply by the communication port of solar controller/inverter)
Auxiliary power supply	8~70VDC (Auxiliary power supply by the battery)
Power consumption	0.3W
Communication baud rate	115200 (Default) 9600
Working environment temperature	-30℃~50℃
Storage temperature	-30℃~80℃
Enclosure	IP30
Dimension	121* 88* 27.5mm
Mounting dimension	69mm
Mounting hole size	Φ4.8
Net Weight	121.8g

### 7 Dimensions

